

MINNESOTA DEPARTMENT OF TRANSPORTATION
THE COUNTY OF OLMSTED
CONSTRUCTION PLAN FOR GRADING, AGGREGATE BASE, CONCRETE AND BITUMINOUS SURFACING & BRIDGE No. 55J65, 55J76, 55J77, 55J78, 55J79, 55J80 & 90780(EXTENSION)

GOVERNING SPECIFICATIONS
THE 2005 EDITION OF THE MINNESOTA DEPARTMENT OF TRANSPORTATION "STANDARD SPECIFICATIONS FOR CONSTRUCTION" SHALL GOVERN.

INDEX

Table with columns SHEET No. and DESCRIPTION. Lists sheet numbers 1 through 299 and their corresponding descriptions, including typical sections, tabulations, bridge details, and erosion control plans.

THIS PLAN CONTAINS 299 SHEETS

DESIGN DESIGNATION: S.A.P. 55-610-22

Table of design data including ADT (Current Year) = 1,159 (2010), ADT (Future Year) = 1,854 (2030), HCA DT (Heavy Commercial) = 5.9%, Functional Classification = Major Collector, 10 Ton Design, Soil Characteristic, R-value = 16, Soil Factor = 130%, No. of Traffic Lanes = 2 at 12 Ft., Shoulder Width = 6 Ft.

Design Speed 55 MPH Based on Stopping Sight Distance
Stopping Sight Distance based on 3.5 Ft. Height of Eye and 2.0 Ft. Height of Object
Design Speed not achieved at: N/A

DESIGN ENGINEER: I HEREBY CERTIFY THAT THIS PLAN WAS PREPARED BY ME OR UNDER MY DIRECT SUPERVISION AND THAT I AM A DULY LICENSED PROFESSIONAL ENGINEER UNDER THE LAWS OF THE STATE OF MINNESOTA.

DATE 4/5/10 REG. NUMBER 19917
PRINTED NAME: KAYE M. BIENIEK
SIGNED NAME: Kaye M. Bieniek COUNTY DESIGN ENGINEER

DESIGNED BY: J. GOODMAN
DATE 4/6/10 REG. NUMBER 10397
APPROVED: Michael Sheehan OLMTED COUNTY ENGINEER

DISTRICT STATE AID ENGINEER: REVIEWED FOR COMPLIANCE WITH STATE-AID RULES/POLICY
DATE: 04/07/10
STATE AID ENGINEER: APPROVED FOR STATE-AID & FEDERAL-AID FUNDING
DATE: 04/07/10

LOCATED ON C.S.A.H. 10 BETWEEN DOVER AND THE JUNCTION OF CSAH 2 (WEST) (GEOGRAPHIC DESCRIPTION)
FROM 188.40 FEET NORTH AND 2.37 FEET WEST OF THE S.E. CORNER OF SEC. 16, T 106 N, R 11 W TO 5.69 FEET NORTH AND 1245.60 FEET EAST OF THE S. 1/4 CORNER OF SEC. 8, T 107 N, R 11 W (LEGAL DESCRIPTION)

S.A.P. NO. 55-610-22
GROSS LENGTH 43111.59 FEET 8.165 MILES
BRIDGES LENGTH 95.69 FEET 0.018 MILES
EXCEPTIONS LENGTH 24.39 FEET 0.005 MILES
NET LENGTH 43087.20 FEET 8.160 MILES

BRIDGE STATIONS

BR. 55J76 - STA. 174+23.98 - STA. 174+46.02
BR. 55J77 - STA. 192+15.77 - STA. 192+34.23
BR. 55J65 - STA. 263+44.75 - STA. 263+59.25
BR. 55583 - STA. 277+96.25 - STA. 278+91.94
BR. 55J78 - STA. 339+75.10 - STA. 339+94.90
BR. 55J79 - STA. 352+49.00 - STA. 352+61.00
BR. 55J80 - STA. 378+86.00 - STA. 378+96.00
BR. 90780 - STA. 509+19.47 - STA. 509+40.21

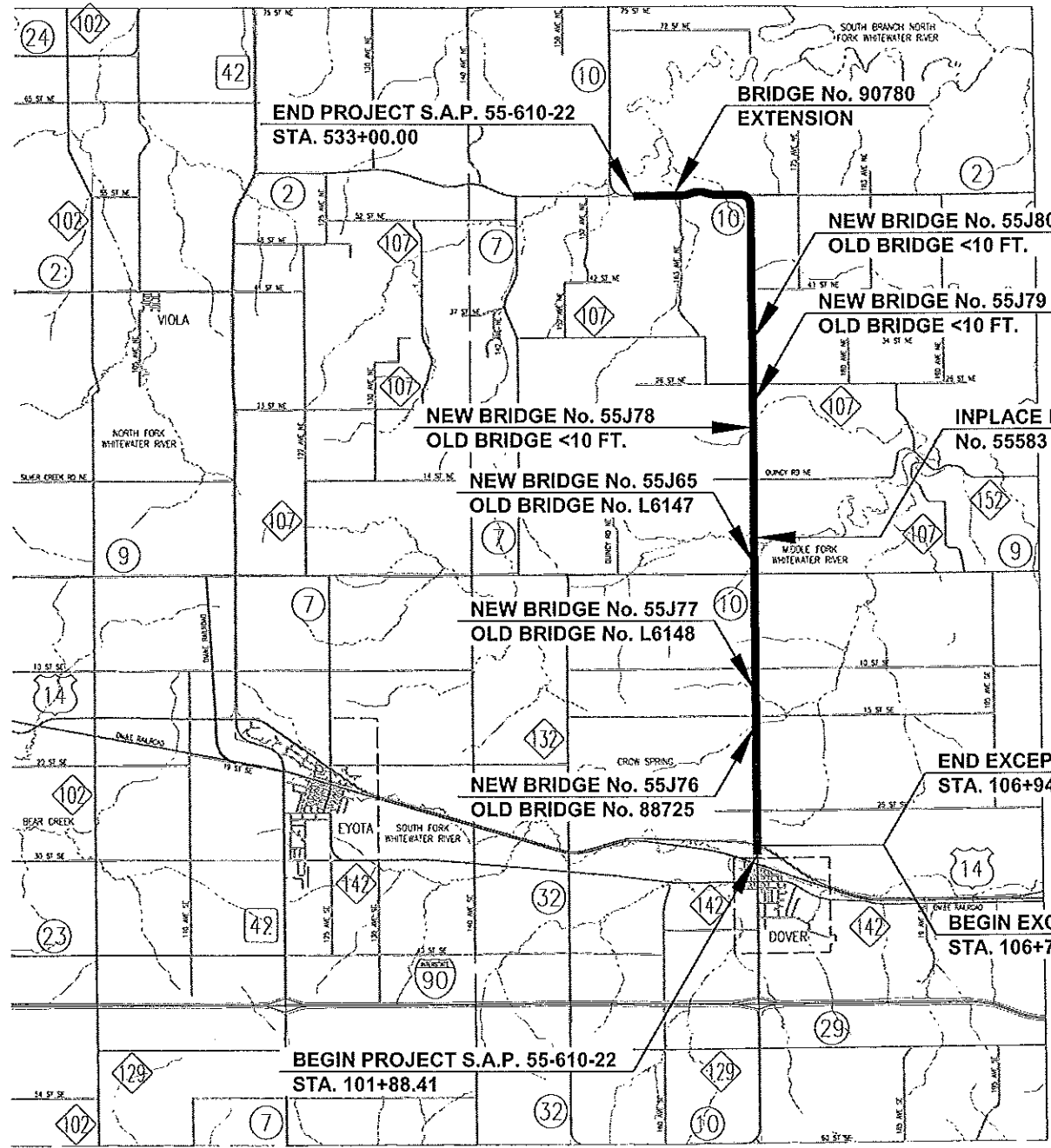

PLAN SYMBOLS
ROAD AND ROADWAY FEATURES
CONSERVATION
RECREATION
ROAD SYSTEM DESIGNATIONS
FARM AND DWELLING UNITS
INDUSTRIAL
COMMERCIAL
PUBLIC SERVICE FACILITIES
CITY CENTERS
MISCELLANEOUS MAP FEATURES
BOUNDARIES
DRAINAGE

SCALES
PLAN: 100 FEET
PROFILE: 100 FEET HORIZ., 10 FEET VERT.
CROSS SECTIONS: 20 FEET HORIZ. and VERT.
INDEX MAP: 1 3/4 MILE

THE SUBSURFACE UTILITY INFORMATION IN THIS PLAN IS UTILITY QUALITY LEVEL D. THIS QUALITY LEVEL WAS DETERMINED ACCORDING TO THE GUIDELINES OF C/ASCE 38-02, ENTITLED "STANDARD GUIDELINES FOR THE COLLECTION AND DEPICTION OF EXISTING SUBSURFACE UTILITY DATA".

STATEMENT OF ESTIMATED QUANTITIES						
SPECIFICATION NO.	ITEM	ITEM NOTES	UNITS	S.A.P. 55-610-22		TOTAL ESTIMATED QUANTITIES
				PARTICIPATING	NON PARTICIPATING	
2021.501	MOBILIZATION		LUMP SUM	1		1
2031.501	FIELD OFFICE, TYPE D		EACH	1		1
2101.501	CLEARING		ACRE	2.77	(P)	2.77
2101.502	CLEARING		TREE	214		214
2101.506	GRUBBING		ACRE	2.77	(P)	2.77
2101.507	GRUBBING		TREE	214		214
2104.501	REMOVE CONCRETE CULVERT		LIN. FT.	613		613
2104.501	REMOVE METAL CULVERT		LIN. FT.	2535		2535
2104.501	REMOVE FENCE	(1)	LIN. FT.	41949		41949
2104.501	REMOVE FOOTING	(2)	LIN. FT.	80		80
2104.501	REMOVE CONCRETE BOX CULVERT		LIN. FT.	162		162
2104.505	REMOVE CONCRETE DRIVEWAY PAVEMENT	(3)	SQ. YD.	27		27
2104.505	REMOVE CONCRETE PAVEMENT		SQ. YD.	254		254
2104.505	REMOVE BITUMINOUS PAVEMENT	(4)	SQ. YD.	120104		120104
2104.507	REMOVE AGGREGATE	(5)	CU. YD.	359		359
2104.509	REMOVE CISTERN	(6)	EACH	1		1
2104.511	SAWING CONCRETE PAVEMENT (FULL DEPTH)		LIN. FT.	60		60
2104.513	SAWING BITUMINOUS PAVEMENT (FULL DEPTH)		LIN. FT.	575		575
2106.607	UNCLASSIFIED EXCAVATION	(7)	CU. YD.	257420	(P)	257420
2106.607	COMMON EMBANKMENT (CV)		CU. YD.	161515	(P)	161515
2123.503	MOTOR GRADER	(1)(8)	HOUR	24		24
2123.507	1.0 CU. YD. SHOVEL	(1)(8)	HOUR	24		24
2123.508	15 CU. YD. SCRAPER	(1)(8)	HOUR	24		24
2123.509	DOZER	(1)(8)	HOUR	24		24
2123.611	INSTRUMENTED COMPACTOR		LUMP SUM	1		1
2130.501	WATER	(1)(9)	M-GALLONS	250		250
2211.501	AGGREGATE BASE, CLASS 2	(10)	TON	6158		6158
2211.501	AGGREGATE BASE, CLASS 5 MOD.	(11)	TON	81902	(P)	81902
2301.531	EXPANSION JOINT DESIGN EBS		LIN. FT.	48		48
2301.538	DOWEL BAR (EPOXY COATED)	(12)	EACH	62064		62064
2301.551	BRIDGE APPROACH PANEL		EACH	2		2
2301.602	DRILL & GROUT DOWEL BAR (EPOXY COATED)		EACH	56		56
2301.602	DRILL & GROUT REINF. BAR (EPOXY COATED)		EACH	58		58
2301.604	CONCRETE PAVEMENT 8"		SQ. YD.	112964	(P)	112964
2301.604	CONCRETE SHOULDER 6"		SQ. YD.	131	(P)	131
2301.608	SUPPLEMENTAL PAVEMENT REINFORCEMENT		POUND	9640		9640
2360.501	TYPE SP 9.5 WEARING COURSE MIX (3C)	(13)	TON	5462		5462
2360.501	TYPE SP 12.5 WEARING COURSE MIX (3C)	(14)	TON	8691		8691
2412.511	6x5 PRECAST CONCRETE BOX CULVERT		LIN. FT.	88		88
2412.511	8x4 PRECAST CONCRETE BOX CULVERT		LIN. FT.	92		92
2412.511	8x5 PRECAST CONCRETE BOX CULVERT		LIN. FT.	168		168
2412.511	10x4 PRECAST CONCRETE BOX CULVERT		LIN. FT.	84		84
2412.511	10x6 PRECAST CONCRETE BOX CULVERT		LIN. FT.	168		168
2412.511	10x10 PRECAST CONCRETE BOX CULVERT		LIN. FT.	58		58
2412.511	12x6 PRECAST CONCRETE BOX CULVERT		LIN. FT.	83		83
2412.511	14x4 PRECAST CONCRETE BOX CULVERT		LIN. FT.	188		188
2412.512	6x5 PC CONC. BOX CULVERT END SECTION		EACH	2		2
2412.512	8x4 PC CONC. BOX CULVERT END SECTION		EACH	2		2
2412.512	8x5 PC CONC. BOX CULVERT END SECTION		EACH	4		4
2412.512	10x4 PC CONC. BOX CULVERT END SECTION		EACH	2		2
2412.512	10x6 PC CONC. BOX CULVERT END SECTION		EACH	4		4
2412.512	10x10 PC CONC. BOX CULVERT END SECTION		EACH	4		4
2412.512	12x6 PC CONC. BOX CULVERT END SECTION		EACH	2		2
2412.512	14x4 PC CONC. BOX CULVERT END SECTION		EACH	4		4
2442.501	REMOVE EXISTING BRIDGE	(15)	LUMP SUM	3		3
2451.507	GRANULAR BEDDING (CV)	(16)	CU. YD.	623	(P)	623

- (1) SPECIFICATION 1903 SHALL NOT APPLY FOR THESE ITEMS.
- (2) CONSISTS OF CONCRETE GARAGE FOOTING AT STA. 108+50 - 50' RT..
- (3) CONSISTS OF CONCRETE DRIVEWAY AT STA. 207+97 - 40' TO 65' RT..
- (4) APPROXIMATE DEPTHS OF INPLACE BITUMINOUS ARE 9" FROM STA. 101+88 TO STA. 258+33, 7" FROM STA. 258+33 TO STA. 293+33, 9" FROM STA. 293+33 TO STA. 482+50, 7" FROM STA. 482+50 TO STA. 513+50 AND 9" FROM STA. 513+50 TO STA. 532+00.
- (5) CONSISTS OF APPROXIMATE 8" DEPTH FROM STA. 275+50 TO STA. 277+96 AND 8" DEPTH FROM STA. 278+92 TO STA. 280+50.
- (6) CONSISTS OF 8' x 9' CONCRETE CISTERN AT STA. 322+86 - 46' LT..
- (7) INCLUDES 39505 CU. YDS. OF TOPSOIL EXCAVATION.
- (8) TO BE USED FOR FIELD TILE RESTORATION AND MISCELLANEOUS SHAPING IN THE FIELD, AS DIRECTED BY THE ENGINEER.
- (9) INCLUDED FOR DUST CONTROL WITHIN THE PROJECT LIMITS ONLY, AS DIRECTED BY THE ENGINEER.
- (10) INCLUDES 3165 TONS FOR SIDE ROADS AND 2961 TONS FOR DRIVEWAYS AND FIELD ENTRANCES.
- (11) INCLUDES 1689 TONS FOR SIDE ROADS AND 670 TONS FOR C.S.A.H. 2 (EAST).
- (12) DOWEL BARS SHALL BE 1-1/4 INCH DIAMETER.
- (13) INCLUDES 316 TONS FOR SIDE ROADS AND 235 TONS FOR DRIVEWAYS.
- (14) INCLUDES 962 TONS FOR SIDE ROADS AND 326 TONS FOR DRIVEWAYS.
- (15) CONSISTS OF BRIDGE No. 88725 AT STA. 174+35.00 - C/L, BRIDGE No. L6148 AT STA. 192+25.00 AND BRIDGE No. L6147 AT STA. 263+52.00.
- (16) GRANULAR BEDDING TO BE USED AT BOX CULVERTS. ALL OTHER CENTERLINE PIPE CULVERTS SHALL BE PLACED ON CLASS "B" BEDDING WHICH SHALL BE INCIDENTAL TO THE PIPE CULVERT ITEM.

STANDARD PLATES	
THE FOLLOWING STANDARD PLATES, APPROVED BY THE FEDERAL HIGHWAY ADMINISTRATION SHALL APPLY ON THIS PROJECT.	
PLATE NO.	DESCRIPTION
1070L	REINFORCED PANEL OVER CULVERTS
1103J	TYPICAL DOWEL BAR ASSEMBLY
1141D	PAVEMENT KEYWAY FOR KEYED JOINT CONSTRUCTION
1150Q	CONSTRUCTION OF HEADER JOINTS
3006G	GASKET JOINT FOR R.C. PIPE
3040F	CORRUGATED METAL PIPE CULVERT
3000L	REINFORCED CONCRETE PIPE
3008G	GASKET JOINT FOR R.C. PIPE
3014J	REINFORCED CONCRETE PIPE ARCH
3040F	CORRUGATED METAL PIPE CULVERT
3100G	CONCRETE APRON FOR REINFORCED CONCRETE PIPE
3110G	CONCRETE APRON FOR REINFORCED CONCRETE PIPE-ARCH
3123J	METAL APRON FOR C.S. PIPE
3124B	METAL APRON CONNECTION
3131C	PRECAST CONCRETE HEADWALL FOR SUBSURFACE DRAINS
3133C	RIPRAP AT RCP OUTLETS
3134C	RIPRAP AT CMP OUTLETS
3145F	CONCRETE PIPE TIES
3221C	CORRUGATED STEEL PIPE COUPLING BAND
4005L	MANHOLE OR CATCH BASIN (DESIGN F)
4006L	MANHOLE OR CATCH BASIN (DESIGN G OR H)
4011E	PRECAST CONCRETE BASE
4101D	RING CASTING FOR MANHOLE OR CATCH BASIN
4110F	COVER CASTING FOR MANHOLE
4129G	CATCH BASIN FRAME CASTING
4151B	GRATE CASTING FOR CATCH BASIN
4160D	CURB BOX CASTING FOR CATCH BASIN
7035M	CONCRETE WALK & CURB RETURNS AT ENTRANCES
7100H	CONCRETE CURB AND GUTTER
7111J	INSTALLATION OF CATCH BASIN CASTINGS
8000I	STANDARD BARRICADES
9000D	APPROACHES AND ENTRANCES
9102D	TURF ESTABLISHMENT AREAS (AT PIPE CULVERT ENDS)

BASIS OF QUANTITY

AGGREGATE BASE, CLASS 2 - 140 LBS./CU. FT. COMPACTED
 AGGREGATE BASE, CLASS 5 MOD. - 140 LBS./CU. FT. COMPACTED
 BITUMINOUS MIXTURE - 110 LBS./SQ. YD./1 INCH DEPTH
 SEED MIXTURE 110 - 100 LBS./ACRE
 SEED MIXTURE 250 - 70 LBS./ACRE
 SEED MIXTURE 325 - 84 LBS./ACRE
 SEED MIXTURE 328 - 88 LBS./ACRE
 MULCH MATERIAL TYPE 1 - 2 TONS/ACRE EXCEPT EROSION BLANKET AND SOD AREAS
 DISK ANCHORING - ALL SEEDING AREAS EXCEPT 1:2 SLOPES AND SOD AREAS
 COMMERCIAL FERTILIZER - 200 LBS./ACRE

UTILITY LOCATIONS	
GOPHER STATE ONE CALL 1-800-252-1166	
CONTRACTOR SHALL VERIFY ALL UNDERGROUND UTILITY LOCATIONS AND ELEVATIONS PRIOR TO CONSTRUCTION. ALL INPLACE UTILITIES MAY NOT BE SHOWN ON THIS PLAN.	

TITLE:
ESTIMATED QUANTITIES

CERTIFIED BY: *Kay M. Kozminsk* REG. NO. 19917 A/5 2010
LICENSED PROFESSIONAL ENGINEER

S.A.P. 55-610-22

Sheet No. 2 of 299 Sheets

STATEMENT OF ESTIMATED QUANTITIES						
SPECIFICATION NO.	ITEM	ITEM NOTES	UNITS	S.A.P. 55-610-22		TOTAL ESTIMATED QUANTITIES
				PARTICIPATING	NON PARTICIPATING	
2501.511	12" CS PIPE CULVERT		LIN. FT.	198		198
2501.511	15" CS PIPE CULVERT		LIN. FT.	37		37
2501.511	18" CS PIPE CULVERT		LIN. FT.	2118		2118
2501.511	24" CS PIPE CULVERT		LIN. FT.	700		700
2501.511	24" RC PIPE CULVERT		LIN. FT.	164		164
2501.511	42" RC PIPE CULVERT		LIN. FT.	90		90
2501.515	12" GS PIPE APRON		EACH	10		10
2501.515	15" GS PIPE APRON		EACH	2		2
2501.515	18" GS PIPE APRON		EACH	94		94
2501.515	24" GS PIPE APRON		EACH	28		28
2501.515	18" RC PIPE APRON		EACH	2		2
2501.515	24" RC PIPE APRON		EACH	6		6
2501.515	42" RC PIPE APRON		EACH	2		2
2501.521	42" SPAN CS PIPE-ARCH CULVERT		LIN. FT.	43		43
2501.521	36" SPAN RC PIPE-ARCH CULVERT CL. IIA		LIN. FT.	262		262
2501.521	44" SPAN RC PIPE-ARCH CULVERT CL. IIA		LIN. FT.	172		172
2501.525	42" SPAN GS PIPE-ARCH APRON		EACH	2		2
2501.525	36" SPAN RC PIPE-ARCH APRON		EACH	6		6
2501.525	44" SPAN RC PIPE-ARCH APRON		EACH	4		4
2502.501	4" PRECAST CONCRETE HEADWALL		EACH	152		152
2502.521	4" I.P. PIPE DRAIN		LIN. FT.	2259		2259
2502.541	4" PERF. P.E. PIPE DRAIN		LIN. FT.	81095		81095
2503.511	18" RC PIPE SEWER CL. IV		LIN. FT.	93		93
2503.511	24" RC PIPE SEWER CL. III		LIN. FT.	188		188
2506.502	CONSTRUCT DRAINAGE STRUCTURE DESIGN F		EACH	1		1
2506.502	CONSTRUCT DRAINAGE STRUCTURE DESIGN G		EACH	1		1
2511.501	RANDOM RIPRAP, CLASS III	(1)	CU. YD.	596		596
2520.501	LEAN MIX BACKFILL		CU. YD.	46	(P)	46
2531.501	CONCRETE CURB & GUTTER DESIGN B424		LIN. FT.	475		475
2531.507	6" CONCRETE DRIVEWAY PAVEMENT		SQ. YD.	24		24
2563.601	TRAFFIC CONTROL		LUMP SUM	1		1
2573.502	SILT FENCE, TYPE MACHINE SLICED	(1) (2)	LIN. FT.	26196		26196
2573.512	TEMPORARY DITCH CHECK, TYPE 1	(1)	LIN. FT.	2550		2550
2573.512	TEMPORARY DITCH CHECK, TYPE 2	(1)	LIN. FT.	1744		1744
2573.513	TEMPORARY DITCH CHECK, TYPE 7	(1)	CU. YD.	100		100
2573.540	FILTER LOG, TYPE STRAW BIOROLL	(1)	LIN. FT.	3696		3696
2573.550	EROSION CONTROL SUPERVISOR		LUMP SUM	1		1

STATEMENT OF ESTIMATED QUANTITIES						
SPECIFICATION NO.	ITEM	ITEM NOTES	UNITS	S.A.P. 55-610-22		TOTAL ESTIMATED QUANTITIES
				PARTICIPATING	NON PARTICIPATING	
2575.501	SEEDING		ACRE	92.0		92.0
2575.502	SEED, MIXTURE 110		POUND	8461		8461
2575.502	SEED, MIXTURE 250		POUND	5800		5800
2575.502	SEED, MIXTURE 325		POUND	55		55
2575.502	SEED, MIXTURE 328		POUND	98		98
2575.505	SODDING TYPE LAWN	(1)	SQ. YD.	35023		35023
2575.511	MULCH MATERIAL, TYPE 1		TON	129.0		129.0
2575.519	DISK ANCHORING		ACRE	64.5		64.5
2575.523	EROSION CONTROL BLANKET, CATEGORY 2	(1)	SQ. YD.	18099		18099
2575.523	EROSION CONTROL BLANKET, CATEGORY 3	(1)	SQ. YD.	48940		48940
2575.523	EROSION CONTROL BLANKET, CATEGORY 4	(1)	SQ. YD.	23757		23757
2575.523	EROSION CONTROL BLANKET, CATEGORY 5	(1)	SQ. YD.	6764		6764
2575.523	EROSION CONTROL BLANKET, CATEGORY 6	(1)	SQ. YD.	1822		1822
2575.532	FERTILIZER, TYPE 1		POUND	18370		18370
2575.570	RAPID STABILIZATION METHOD 1		ACRE	10		10
2580.603	INTERIM PAVEMENT MARKING		LIN. FT.	34592		34592
2582.502	4" SOLID LINE WHITE - EPOXY		LIN. FT.	86672		86672
2582.502	4" SOLID LINE YELLOW - EPOXY		LIN. FT.	19863		19863
2582.502	4" BROKEN LINE YELLOW - EPOXY		LIN. FT.	7939		7939
2582.502	4" DOUBLE SOLID LINE YELLOW - EPOXY		LIN. FT.	3395		3395

- (1) SPECIFICATION 1903 SHALL NOT APPLY FOR THESE ITEMS.
- (2) ITEM INCLUDES MAINTENANCE DURING THE LENGTH OF THE CONTRACT AND REMOVAL ONCE TURF HAS BEEN ESTABLISHED.

BASIS OF QUANTITY

AGGREGATE BASE, CLASS 2 -- 140 LBS./CU. FT. COMPACTED
 AGGREGATE BASE, CLASS 5 MOD. -- 140 LBS./CU. FT. COMPACTED
 BITUMINOUS MIXTURE -- 110 LBS./SQ. YD./1 INCH DEPTH
 SEED MIXTURE 110 -- 100 LBS./ACRE
 SEED MIXTURE 250 -- 70 LBS./ACRE
 SEED MIXTURE 325 -- 84 LBS./ACRE
 SEED MIXTURE 328 -- 88 LBS./ACRE
 MULCH MATERIAL TYPE 1 -- 2 TONS/ACRE EXCEPT EROSION BLANKET AND SOD AREAS
 DISK ANCHORING -- ALL SEEDING AREAS EXCEPT 1:2 SLOPES AND SOD AREAS
 COMMERCIAL FERTILIZER -- 200 LBS./ACRE

CERTIFIED BY *Kay M. Kozminski* REG. NO. 19917 4/5 2010
LICENSED PROFESSIONAL ENGINEER

S.A.P. 55-610-22

TITLE:
ESTIMATED QUANTITIES

Sheet No. 3 of 299 Sheets

ALL UTILITY POLES AND OTHER UNYIELDING OBJECTS SHALL BE REMOVED AND RELOCATED OUTSIDE OF THE RECOVERY AREA.

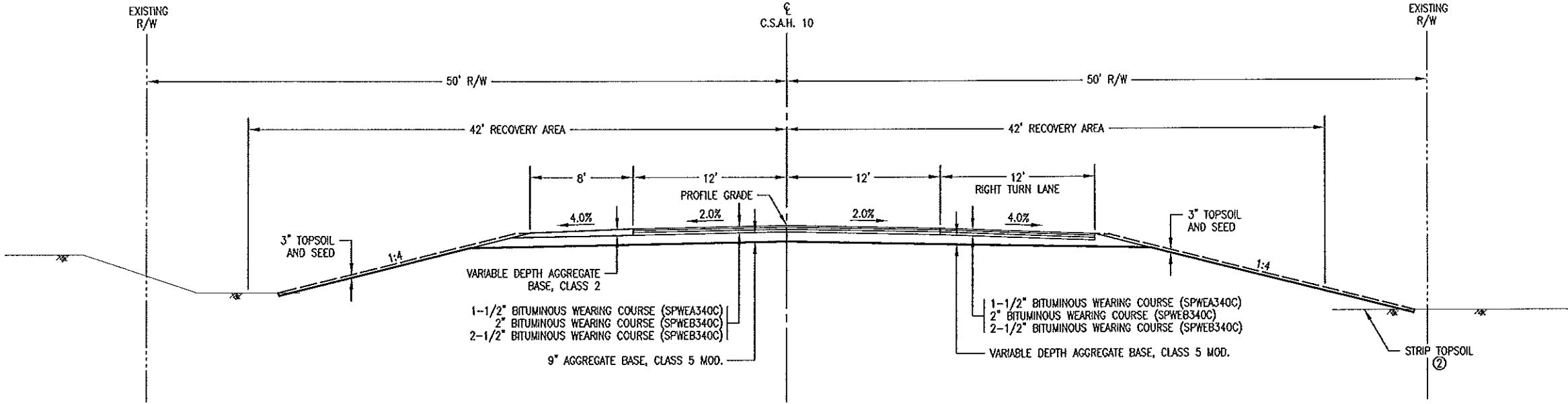

TYPICAL SECTION
STA. 101+88.41 TO STA. 106+70.56

- NOTES:
- ① SEE SUPERELEVATION DIAGRAM AND CROSS SECTIONS FOR ADDITIONAL CROSS SLOPE INFORMATION.
 - ② SALVAGE THE EXISTING TOPSOIL AND USE AS SLOPE DRESSING TO THE EXTENT AVAILABLE. TOPSOIL EXCAVATION SHALL BE INCLUDED IN UNCLASSIFIED EXCAVATION FOR PAYMENT AND NO ADDITIONAL COMPENSATION WILL BE MADE FOR STOCKPILING AND RESPREADING OF THE TOPSOIL.
 - ③ SEE PLAN AND PROFILE SHEETS AND CROSS SECTIONS FOR TEMPORARY EASEMENT INFORMATION.

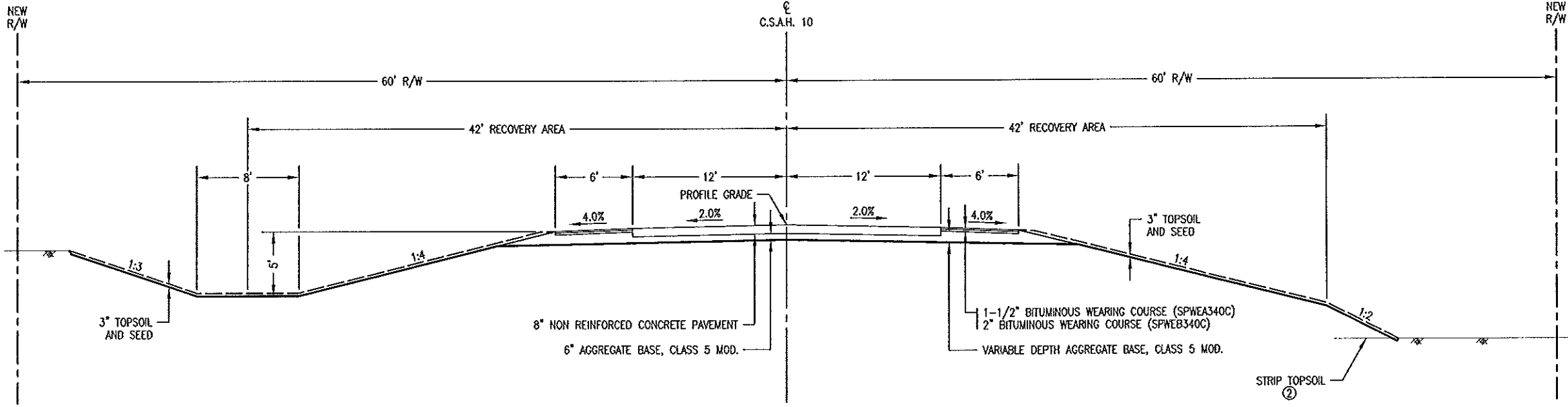

TYPICAL SECTION
STA. 106+94.94 TO STA. 531+50.00

FILE NAME: P306TY01.DWG DATE: 04-05-10

CERTIFIED BY *Kay M. Dzieniek* REG. NO. 19917 4/5 2010
LICENSED PROFESSIONAL ENGINEER

S.A.P. 55-610-22

TITLE:
TYPICAL SECTIONS
Sheet No. 4 of 299 Sheets

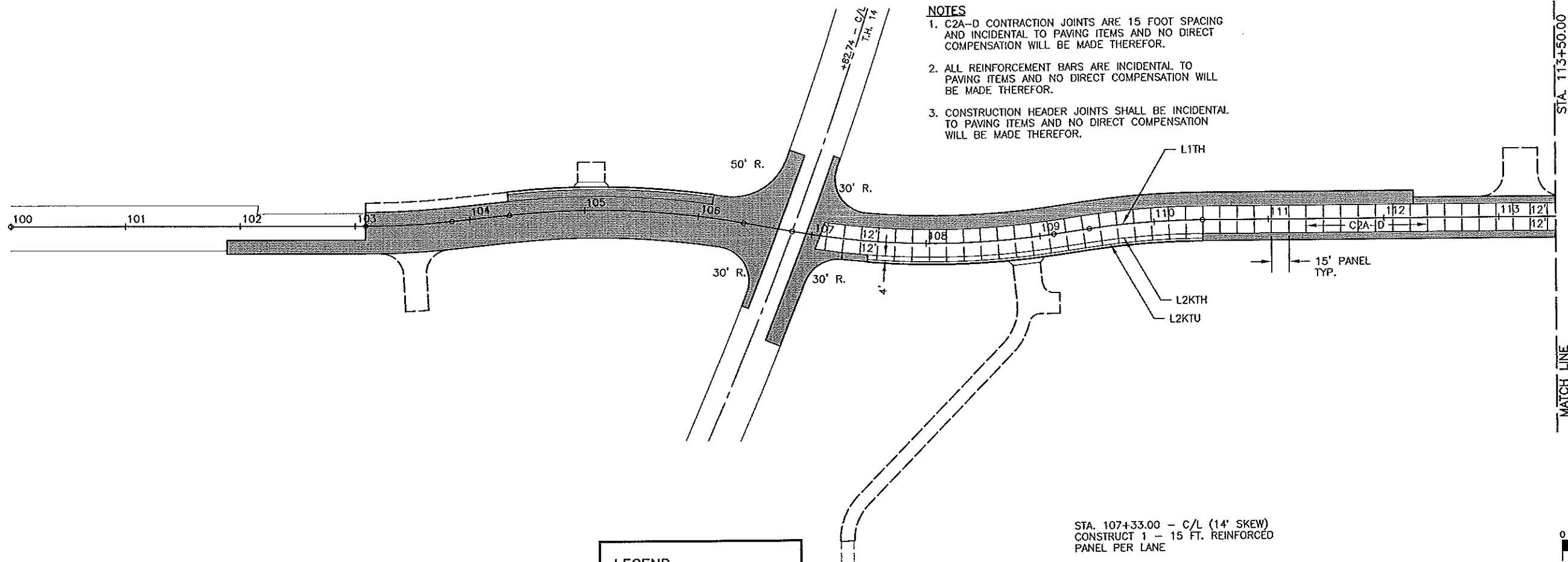

- NOTES**
1. C2A-D CONTRACTION JOINTS ARE 15 FOOT SPACING AND INCIDENTAL TO PAVING ITEMS AND NO DIRECT COMPENSATION WILL BE MADE THEREFOR.
 2. ALL REINFORCEMENT BARS ARE INCIDENTAL TO PAVING ITEMS AND NO DIRECT COMPENSATION WILL BE MADE THEREFOR.
 3. CONSTRUCTION HEADER JOINTS SHALL BE INCIDENTAL TO PAVING ITEMS AND NO DIRECT COMPENSATION WILL BE MADE THEREFOR.

LEGEND

BITUMINOUS SURFACING

STA. 107+33.00 - C/L (14' SKEW)
 CONSTRUCT 1 - 15 FT. REINFORCED
 PANEL PER LANE

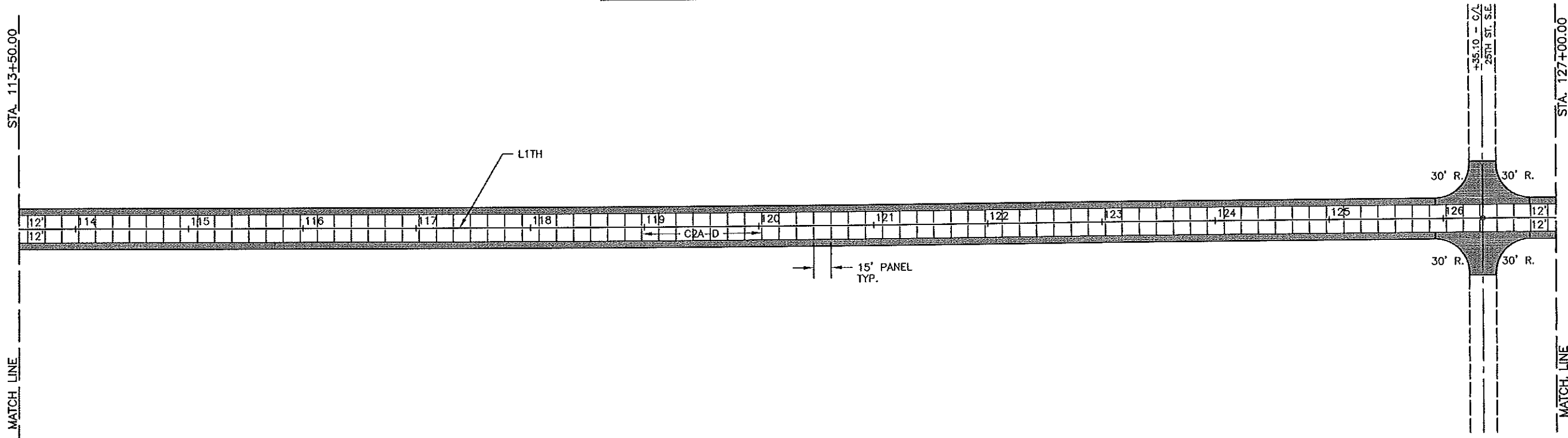
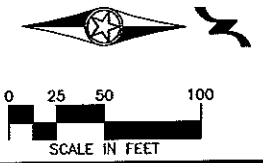

FILE NAME: P006L01.DWG DATE: 02-04-10

CERTIFIED BY *Kay M. Parnick* REG. NO. 19917 4/5 2010
LICENSED PROFESSIONAL ENGINEER

S.A.P. 55-610-22

TITLE: **C.S.A.H. No. 10**
 SURFACING PLAN
 STA. 100+00.00 to STA. 127+00.00
 Sheet No. 64 of 299 Sheets

NOTES

1. C2A-D CONTRACTION JOINTS ARE 15 FOOT SPACING AND INCIDENTAL TO PAVING ITEMS AND NO DIRECT COMPENSATION WILL BE MADE THEREFOR.
2. ALL REINFORCEMENT BARS ARE INCIDENTAL TO PAVING ITEMS AND NO DIRECT COMPENSATION WILL BE MADE THEREFOR.
3. CONSTRUCTION HEADER JOINTS SHALL BE INCIDENTAL TO PAVING ITEMS AND NO DIRECT COMPENSATION WILL BE MADE THEREFOR.

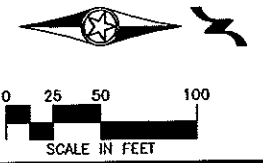
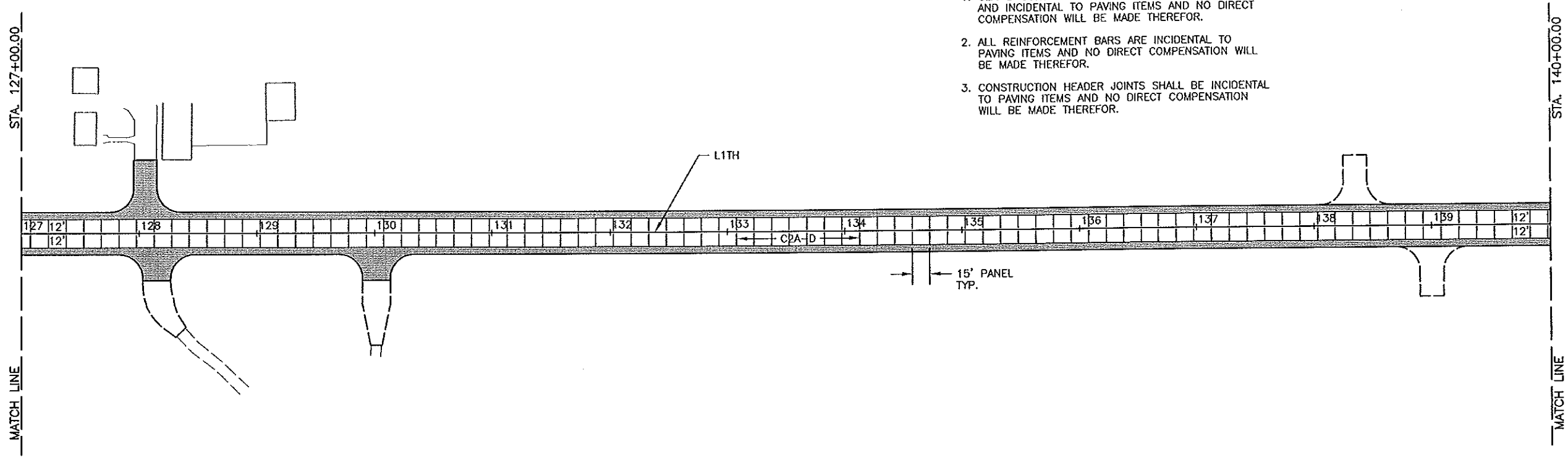

LEGEND

BITUMINOUS SURFACING

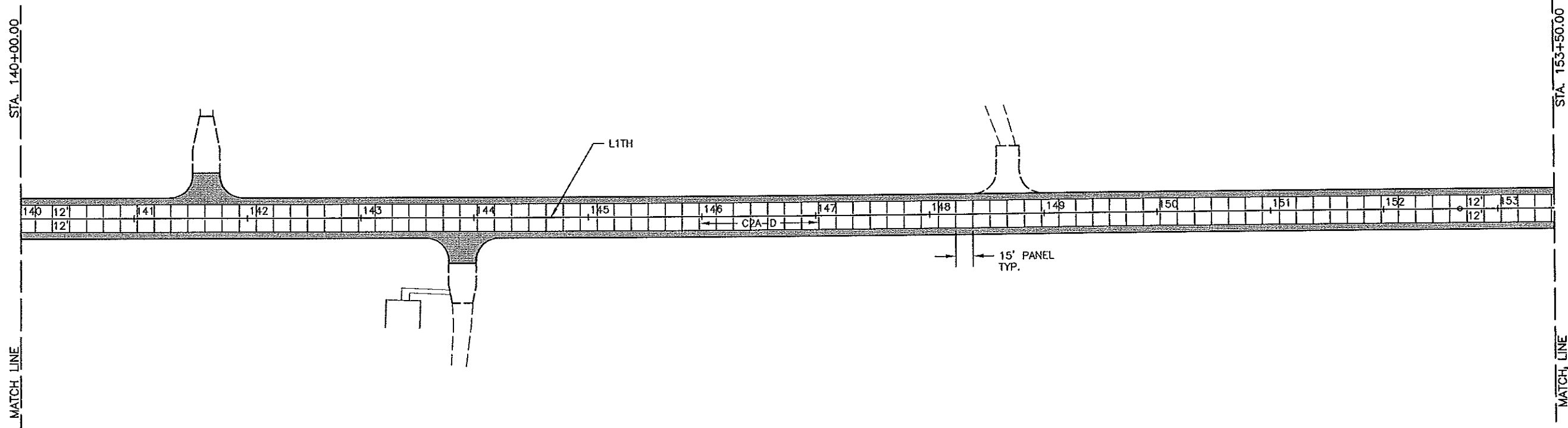

STA. 148+00.00 - C/L
 CONSTRUCT 2 - 15 FT. REINFORCED
 PANELS PER LANE

TITLE: **C.S.A.H. No. 10**
 SURFACING PLAN
 STA. 127+00.00 to STA. 153+50.00

CERTIFIED BY *Kareem M. Banih* REG. NO. 19917 4/5 2010
LICENSED PROFESSIONAL ENGINEER

S.A.P. 55-610-22

Sheet No. 65 of 299 Sheets

FILE NAME: P005L02.DWG DATE: 03-04-10

- NOTES**
1. C2A-D CONTRACTION JOINTS ARE 15 FOOT SPACING AND INCIDENTAL TO PAVING ITEMS AND NO DIRECT COMPENSATION WILL BE MADE THEREFOR.
 2. ALL REINFORCEMENT BARS ARE INCIDENTAL TO PAVING ITEMS AND NO DIRECT COMPENSATION WILL BE MADE THEREFOR.
 3. CONSTRUCTION HEADER JOINTS SHALL BE INCIDENTAL TO PAVING ITEMS AND NO DIRECT COMPENSATION WILL BE MADE THEREFOR.

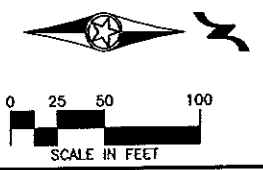
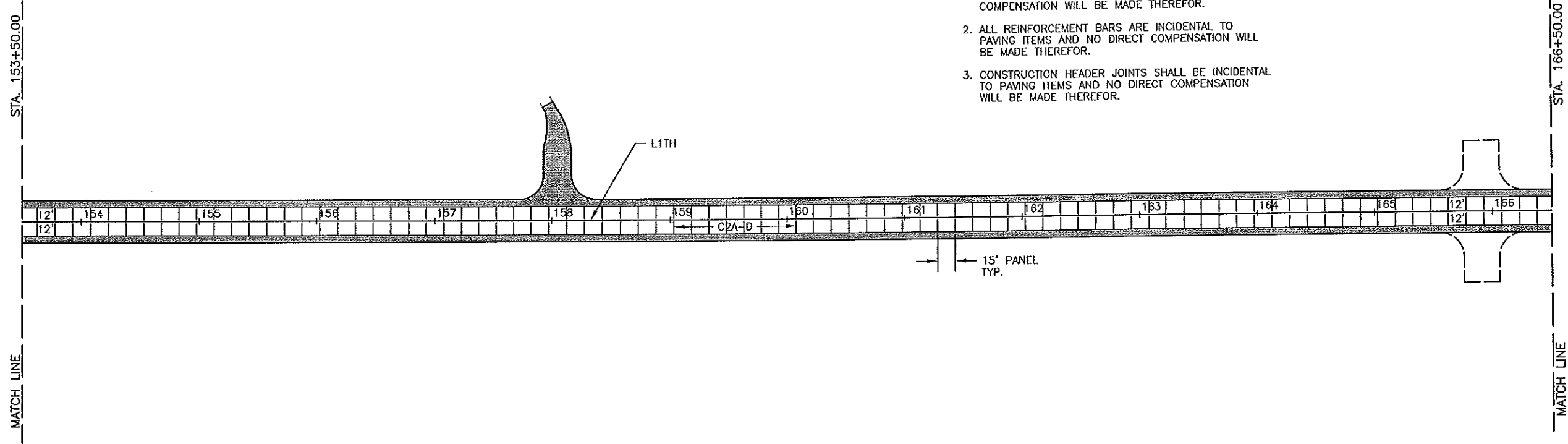

LEGEND

BITUMINOUS SURFACING 

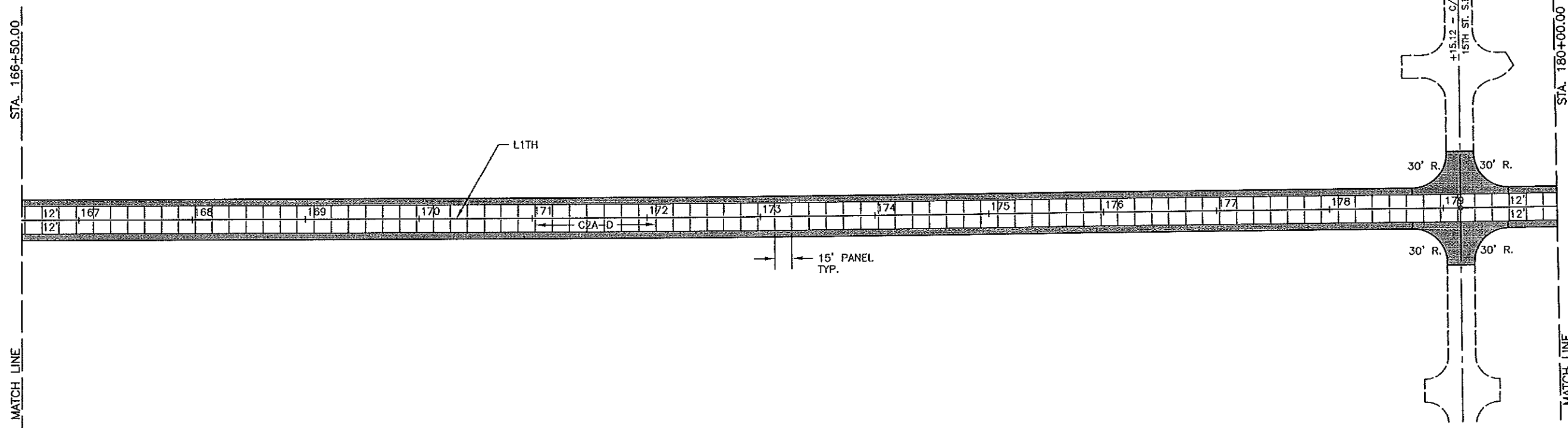

STA. 174+35.00 - C/L (8' SKEW)
 CONSTRUCT 4 - 15 FT. REINFORCED
 PANELS PER LANE

TITLE: **C.S.A.H. No. 10**
 SURFACING PLAN
 STA. 153+50.00 to STA. 180+00.00

CERTIFIED BY *Kay M. Koehn* REG. NO. 19917 4/5 20 10
LIC. IN SD PROFESSIONAL ENGINEER

S.A.P. 55-610-22

Sheet No. 66 of 299 Sheets

FILE NAME: P305L03.DWG DATE: 03-04-10

NOTES

1. C2A-D CONTRACTION JOINTS ARE 15 FOOT SPACING AND INCIDENTAL TO PAVING ITEMS AND NO DIRECT COMPENSATION WILL BE MADE THEREFOR.
2. ALL REINFORCEMENT BARS ARE INCIDENTAL TO PAVING ITEMS AND NO DIRECT COMPENSATION WILL BE MADE THEREFOR.
3. CONSTRUCTION HEADER JOINTS SHALL BE INCIDENTAL TO PAVING ITEMS AND NO DIRECT COMPENSATION WILL BE MADE THEREFOR.

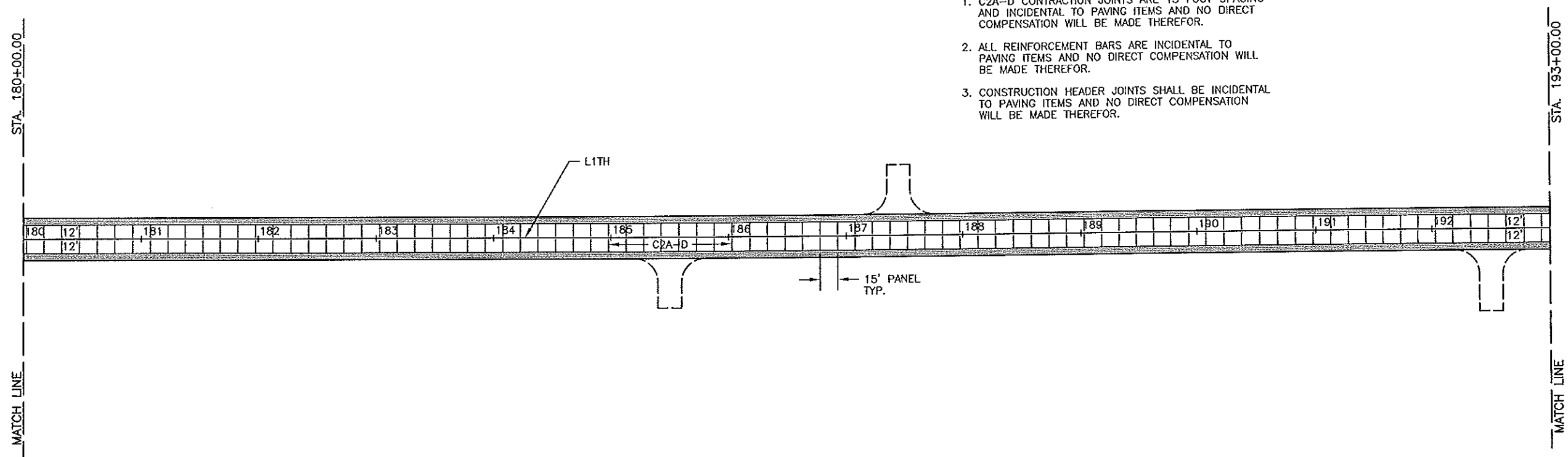

STA. 192+25.00 - C/L (15' SKEW)
 CONSTRUCT 3 - 15 FT. REINFORCED
 PANELS PER LANE

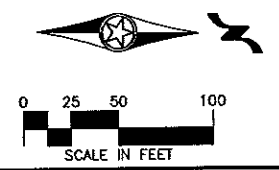

LEGEND

BITUMINOUS SURFACING 

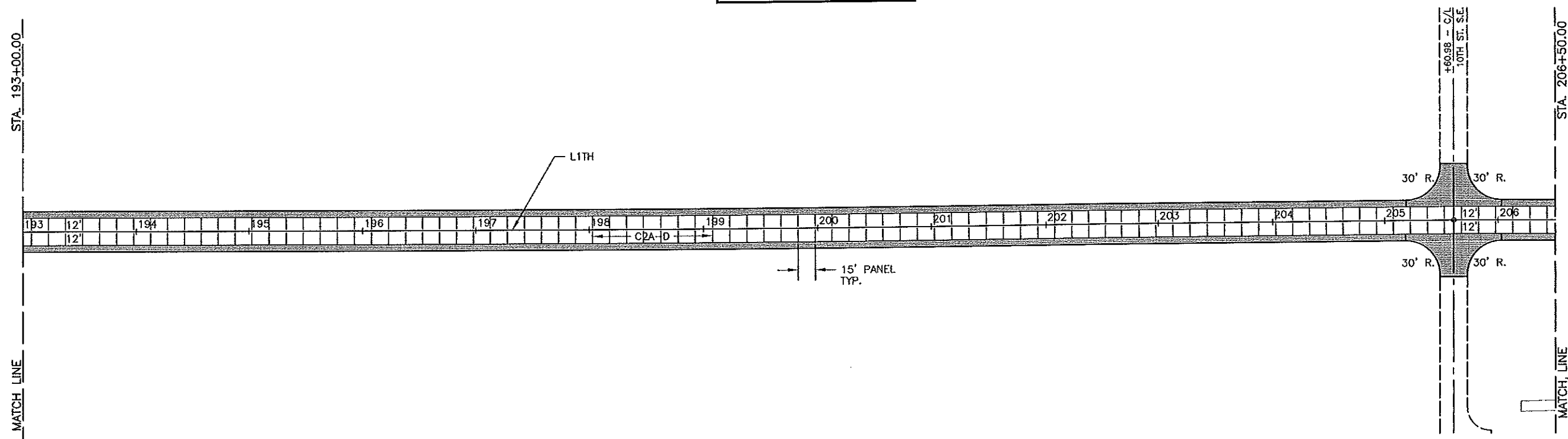

TITLE: **C.S.A.H. No. 10**
 SURFACING PLAN
 STA. 180+00.00 to STA. 206+50.00

CERTIFIED BY *Kay M. Pienick* REG. NO. 19917 4/5 2010
DC 157 PROFESSIONAL ENGINEER

S.A.P. 55-610-22

Sheet No. 67 of 299 Sheets

NOTES

1. C2A-D CONTRACTION JOINTS ARE 15 FOOT SPACING AND INCIDENTAL TO PAVING ITEMS AND NO DIRECT COMPENSATION WILL BE MADE THEREFOR.
2. ALL REINFORCEMENT BARS ARE INCIDENTAL TO PAVING ITEMS AND NO DIRECT COMPENSATION WILL BE MADE THEREFOR.
3. CONSTRUCTION HEADER JOINTS SHALL BE INCIDENTAL TO PAVING ITEMS AND NO DIRECT COMPENSATION WILL BE MADE THEREFOR.

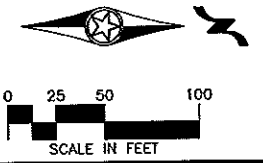
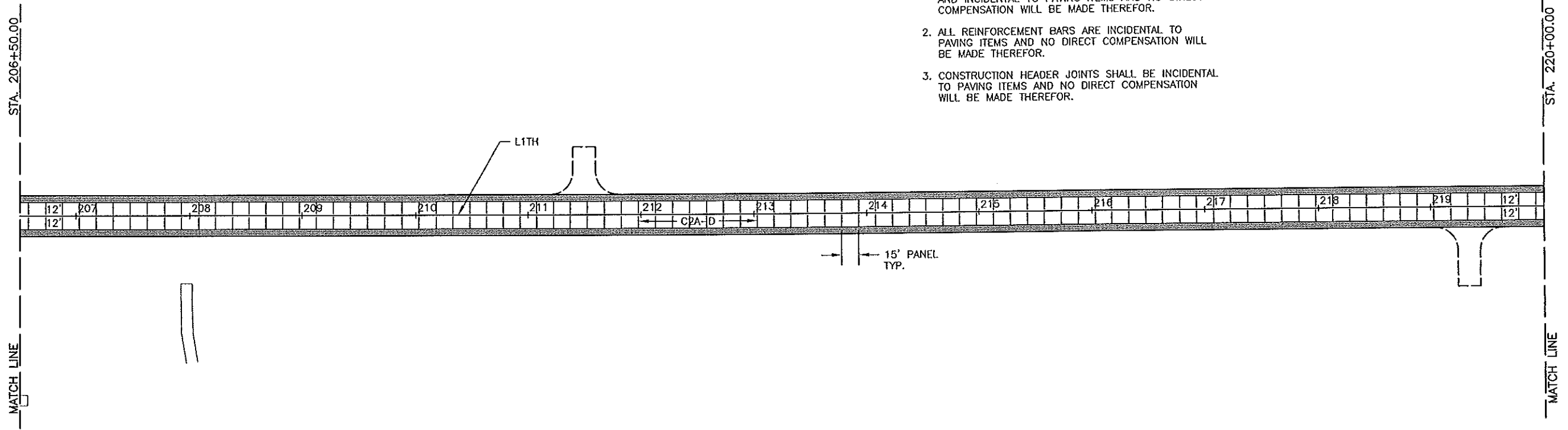

LEGEND

BITUMINOUS SURFACING

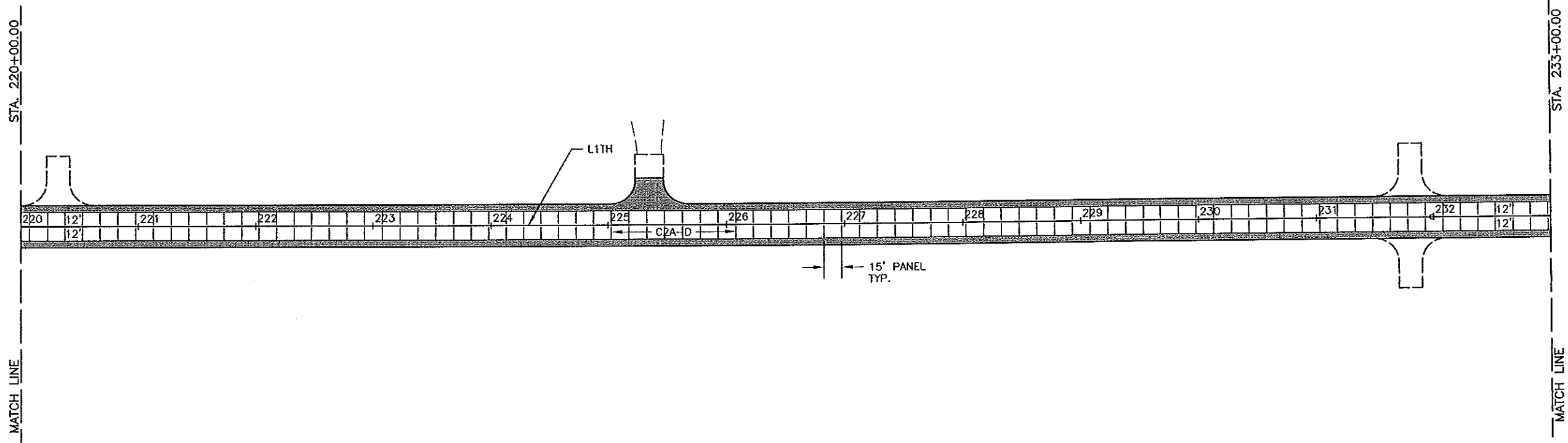

STA. 222+13.00 - C/L
 CONSTRUCT 2 - 15 FT. REINFORCED
 PANELS PER LANE

TITLE: **C.S.A.H. No. 10**
 SURFACING PLAN
 STA. 206+50.00 to STA. 233+00.00

CERTIFIED BY *Kay M. Kienick* REG. NO. 19917 4/5 20 10
LIC. IN THE PROFESSION OF PROFESSIONAL ENGINEER

S.A.P. 55-610-22

Sheet No. 68 of 299 Sheets

FILE NAME: P3068105.DWG DATE: 03-04-10

NOTES

1. C2A-D CONTRACTION JOINTS ARE 15 FOOT SPACING AND INCIDENTAL TO PAVING ITEMS AND NO DIRECT COMPENSATION WILL BE MADE THEREFOR.
2. ALL REINFORCEMENT BARS ARE INCIDENTAL TO PAVING ITEMS AND NO DIRECT COMPENSATION WILL BE MADE THEREFOR.
3. CONSTRUCTION HEADER JOINTS SHALL BE INCIDENTAL TO PAVING ITEMS AND NO DIRECT COMPENSATION WILL BE MADE THEREFOR.

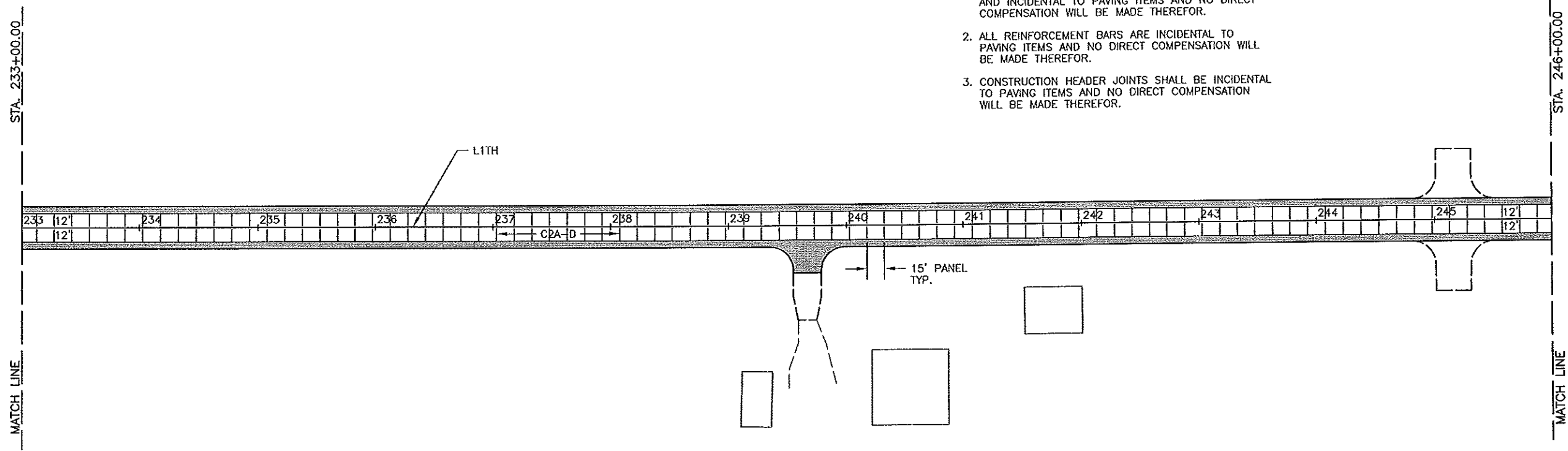

STA. 239+00.00 - C/L
 CONSTRUCT 2 - 15 FT. REINFORCED
 PANELS PER LANE

LEGEND

BITUMINOUS SURFACING

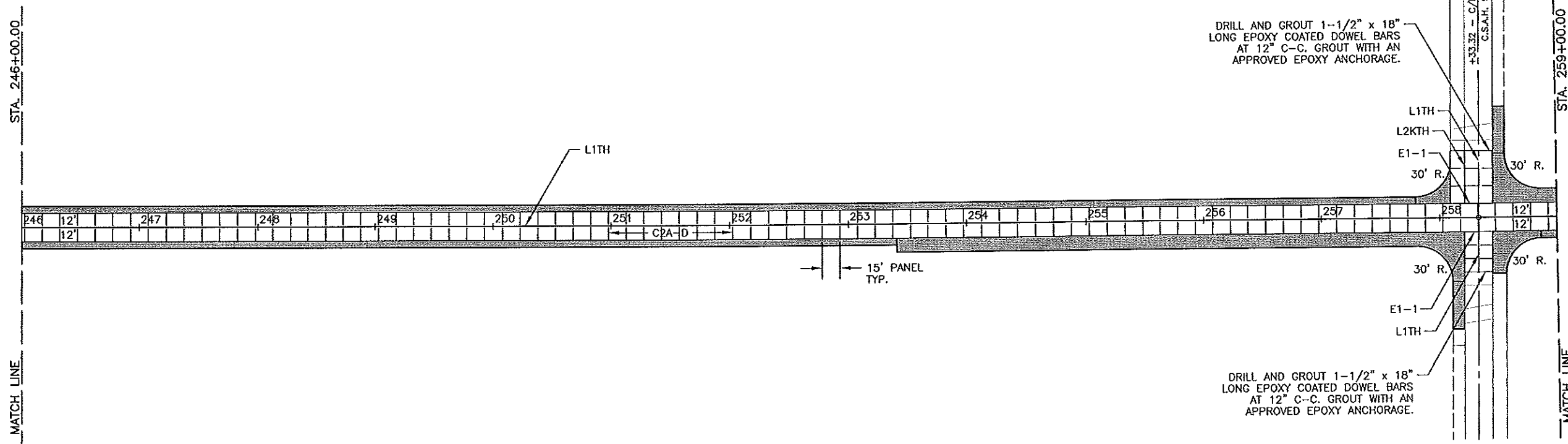
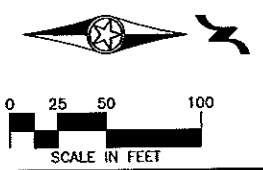

DRILL AND GROUT 1-1/2" x 18"
 LONG EPOXY COATED DOWEL BARS
 AT 12" C-C. GROUT WITH AN
 APPROVED EPOXY ANCHORAGE.

DRILL AND GROUT 1-1/2" x 18"
 LONG EPOXY COATED DOWEL BARS
 AT 12" C-C. GROUT WITH AN
 APPROVED EPOXY ANCHORAGE.



FILE NAME: P306105.DWG DATE: 03-04-10

CERTIFIED BY *Kay M. Kinnick* REG. NO. 19917 4/5 2010
LIC. ROAD PROFESSIONAL ENGINEER

S.A.P. 55-610-22

TITLE:
C.S.A.H. No. 10
 SURFACING PLAN
 STA. 233+00.00 to STA. 259+00.00
 Sheet No. 69 of 299 Sheets

NOTES

1. C2A-D CONTRACTION JOINTS ARE 15 FOOT SPACING AND INCIDENTAL TO PAVING ITEMS AND NO DIRECT COMPENSATION WILL BE MADE THEREFOR.
2. ALL REINFORCEMENT BARS ARE INCIDENTAL TO PAVING ITEMS AND NO DIRECT COMPENSATION WILL BE MADE THEREFOR.
3. CONSTRUCTION HEADER JOINTS SHALL BE INCIDENTAL TO PAVING ITEMS AND NO DIRECT COMPENSATION WILL BE MADE THEREFOR.

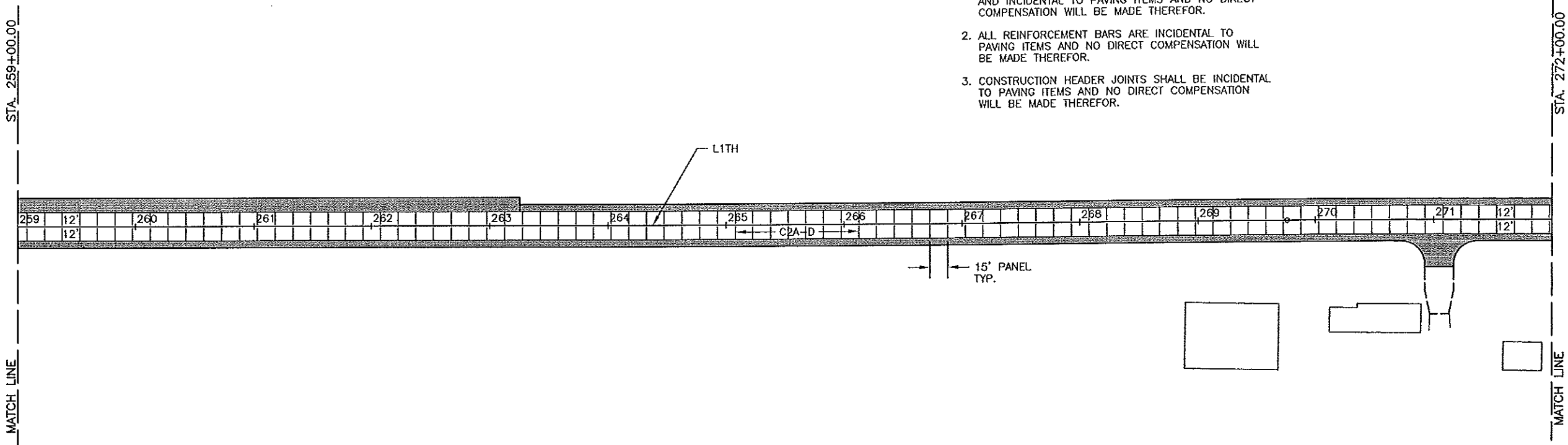

STA. 263+52.00 - C/L (15' SKEW)
CONSTRUCT 3 - 15 FT. REINFORCED
PANELS PER LANE

LEGEND

BITUMINOUS SURFACING

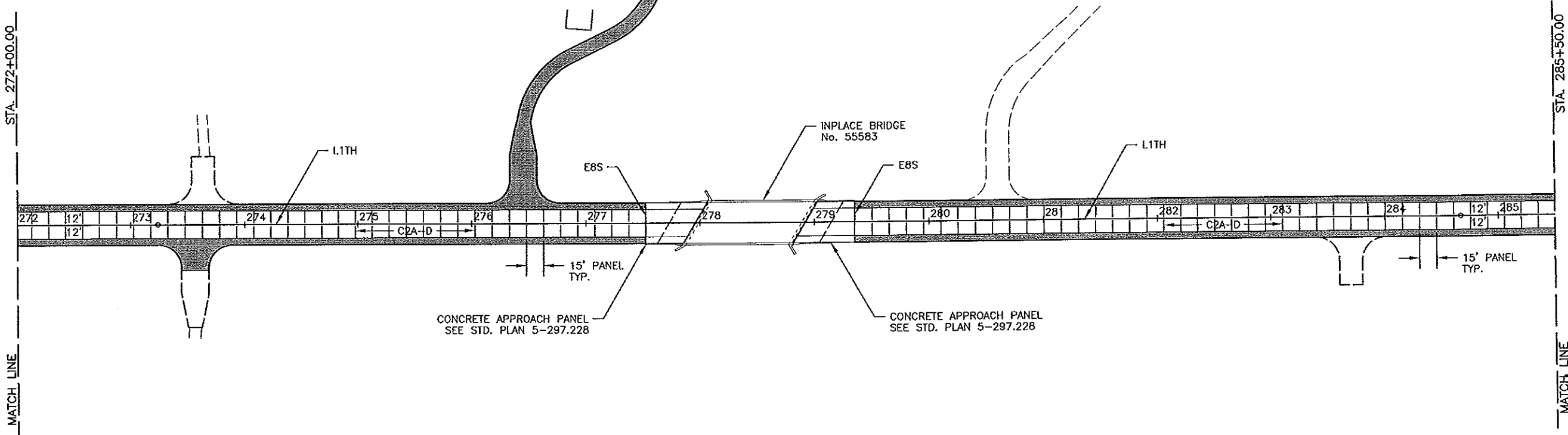
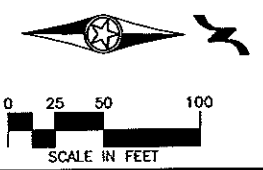

FILE NAME: P2056107.DWG DATE: 03-04-10

CERTIFIED BY *Kevin M. Brumick* REG. NO. 19917 4/5 2010
LICENSED PROFESSIONAL ENGINEER

S.A.P. 55-610-22

TITLE: **C.S.A.H. No. 10**
SURFACING PLAN
STA. 259+00.00 to STA. 285+50.00
Sheet No. 70 of 299 Sheets

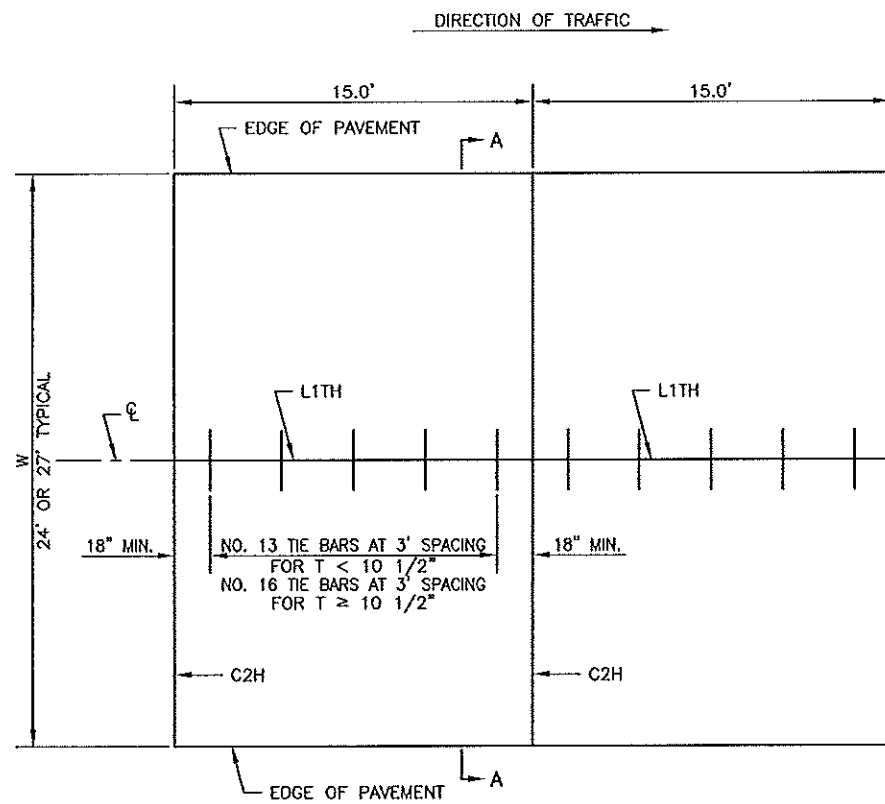

MAINLINE PAVEMENT
UNDOWELED

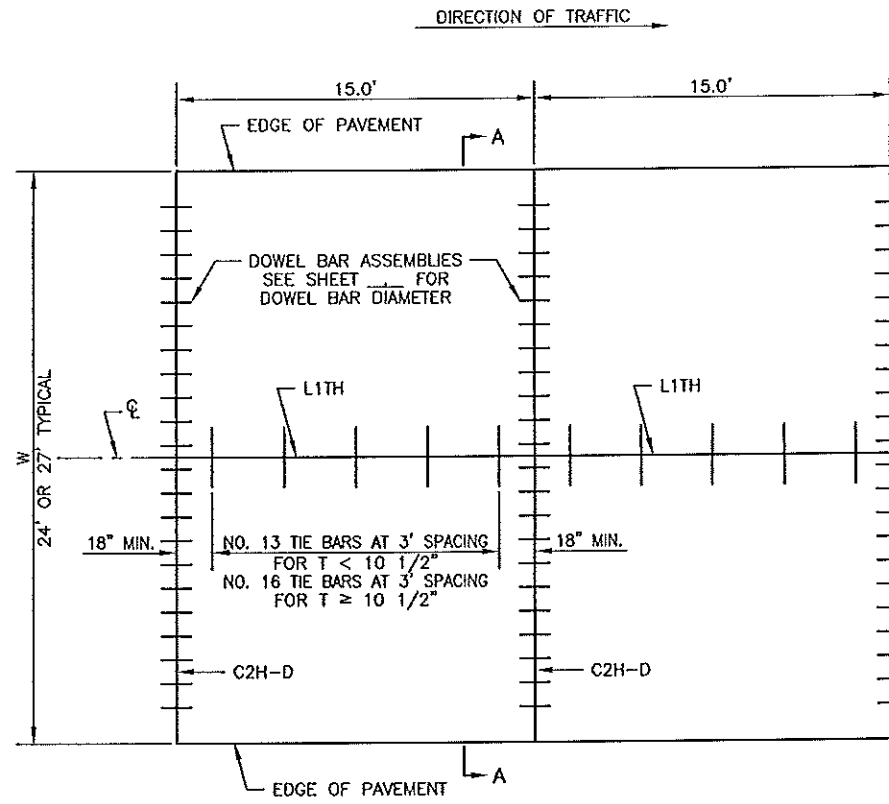

MAINLINE PAVEMENT
DOWELED

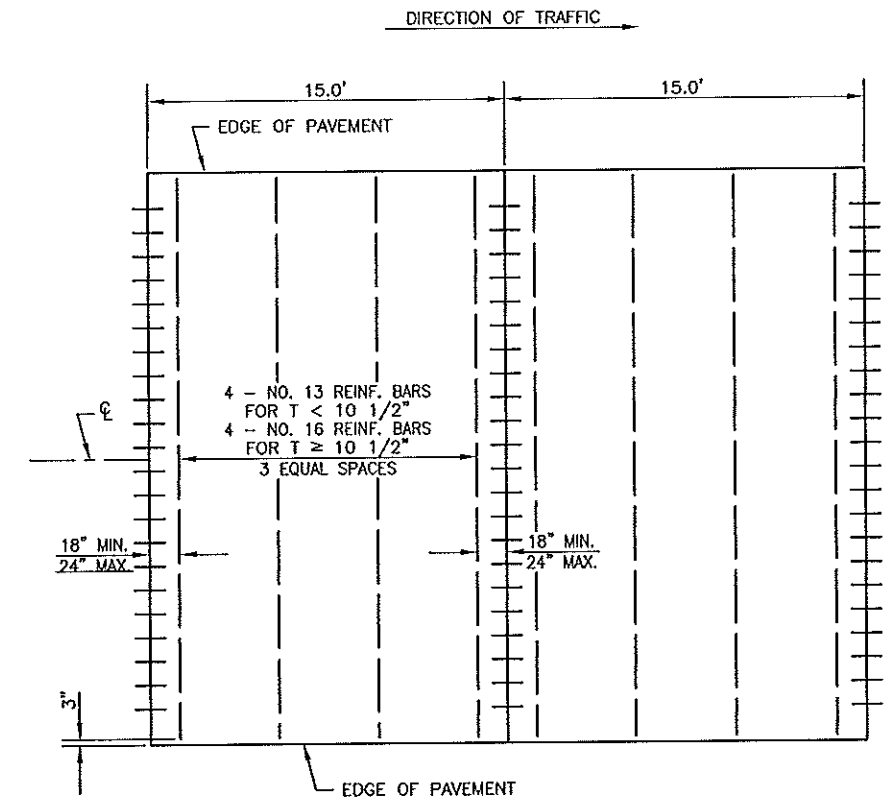

PANEL REINFORCEMENT

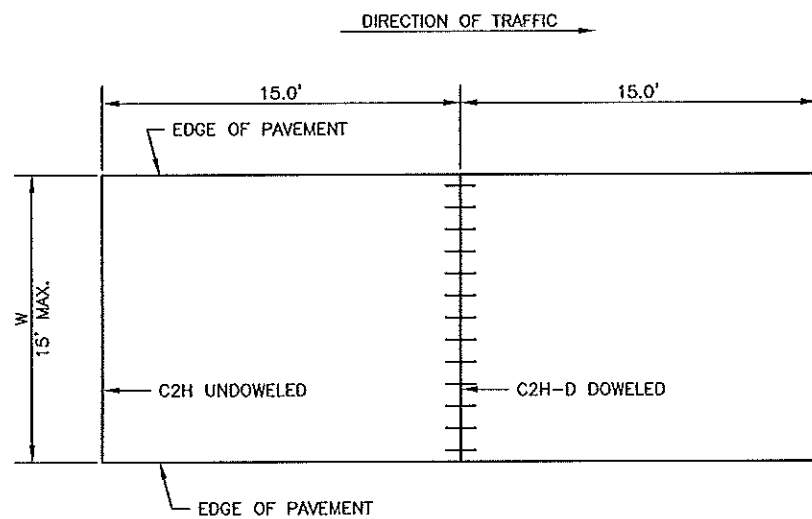

PAVEMENT 2 FT. THRU 15 FT. WIDTH

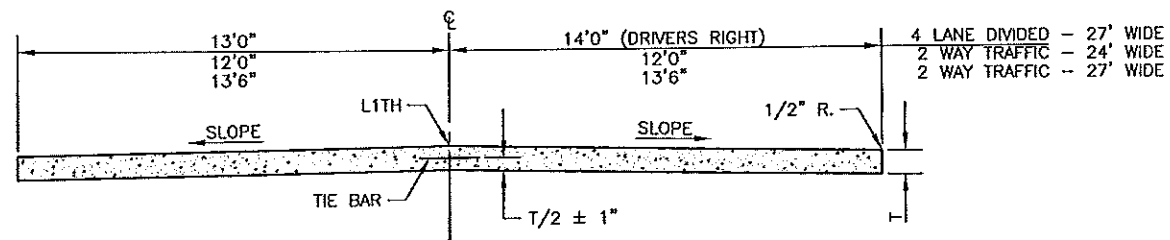

SECTION A-A

GENERAL NOTES:

ALL REBARS ARE IN METRIC DESIGNATIONS

SEE TYPICAL SECTIONS AND PLAN SHEETS FOR CROSS SLOPES AND PAVEMENT THICKNESS, T.

DOWEL BAR ASSEMBLIES, WHEN REQUIRED, SHALL BE SIMILAR TO THOSE SHOWN ON STANDARD PLATE 1103.

ALL REINFORCING BARS SHALL BE EPOXY COATED AND COMPLY WITH SPEC. 3301.

FOR SUPPLEMENTAL PAVEMENT REINFORCEMENT, SEE STANDARD PLATE 1070.

PANEL REINFORCEMENT: PLACE IN PANELS WHERE PAVEMENT WIDTH EXCEEDS 15.0' WITHOUT A LONGITUDINAL JOINT. PLACEMENT DEPTH SHALL BE PLANNED $T/2 \pm 1"$. IT IS PREFERRED TO ADD A LONGITUDINAL JOINT RATHER THAN PAVE GREATER THAN 15' IN WIDTH.

FILE NAME: P305-217A.DWG DATE: 03-04-10

STANDARD SHEET NO.
5-297.217 (1 OF 2)

TITLE:

CONCRETE MAINLINE PAVEMENT
15.0 FT. PANEL LENGTH
RURAL

REFERENCE DATE
01-05-2010

STANDARD APPROVED:
NOT APPROVED

CERTIFIED BY *Kay M. Bensch* REG. NO. 19917 4/5 2010
LICENSED PROFESSIONAL ENGINEER

State Proj. No. S.A.P. 55-610-22

Sheet No. 81 of 299 Sheets

REQUIRED DIMENSIONS	
JOINT TYPE	TRANSVERSE
NOMINAL SEALER SIZE	1 1/16" USE IN ALL 3/8" JOINTS
A	0.69" +0.13" -0.05"
B	0.08" ±0.02"
C	0.25" MIN.
D	0.63" MIN.

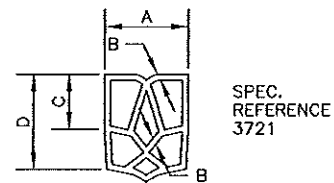

TYPICAL SHAPE FOR SATISFACTORY INSTALLATION IN JOINT (5 CELL MIN.)

NOTES:

"A" DIMENSION SHALL APPLY AT ANY POINT THROUGHOUT "C" DEPTH. IN ITS FINAL POSITION, THE TOP CORNERS OF THE PREFORMED JOINT SEALER SHALL BE PLACED NOT LESS THAN 1/8 IN., NOR MORE THAN 5/16 IN. BELOW THE PAVEMENT SURFACE.

SHARP INTERNAL CORNERS WILL NOT BE PERMITTED. ALL CORNERS SHALL BE PROVIDED WITH SUITABLE FILLET. CURRENTLY APPROVED CONFIGURATIONS ARE ON FILE IN THE MATERIALS ENGINEERING SECTION, MINNESOTA DEPARTMENT OF TRANSPORTATION.

CONTRACTION JOINT SEALER
PREFORMED ELASTIC TYPE

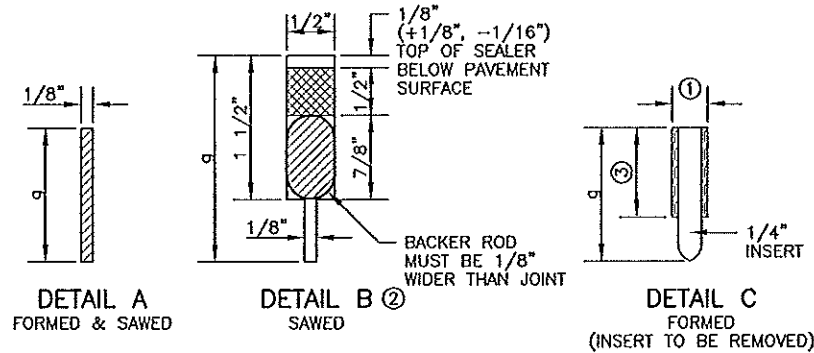

CONTRACTION JOINT CLASS DESIGNATION, DETAIL & SEALER SPEC. TABLE

CLASS DESIGNATION		JOINT DETAIL	JOINT SEALER SPEC.
WITHOUT DOWELS	WITH DOWELS		
C1A	C1A-D	A	UNSEALED
C2A	C2A-D	A	3725
C2B	C2B-D	B	3725
C2X	C2X-D	B OR C	3725
C3D	C3D-D	D	3721
C3X	C3X-D	C OR D	3721
C4E	C4E-D	E	3722

DOWEL BAR DIAMETER TABLE

PAVEMENT THICKNESS T	DOWEL BAR DIAMETER
6" - 6-1/2"	1"
7" - 10"	1-1/4"
10-1/2" - 14"	1-1/2"

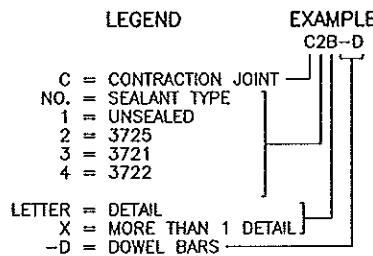
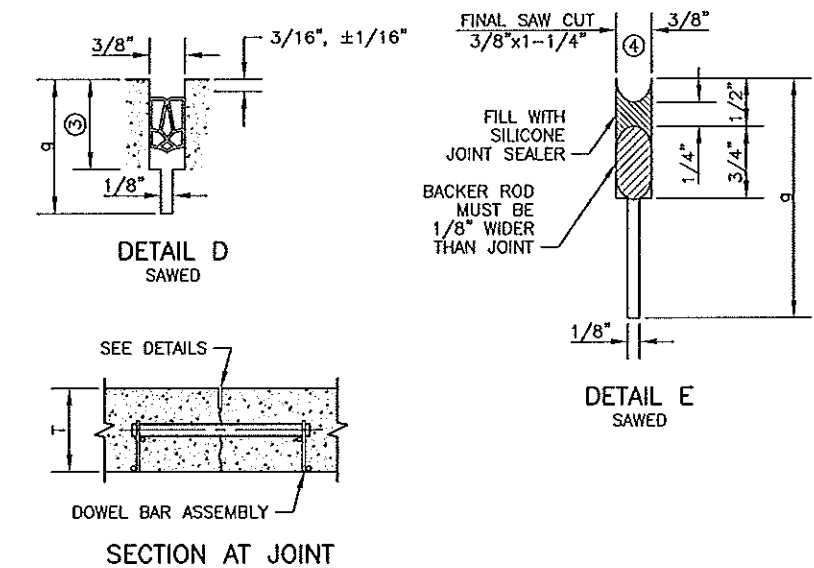

NOTES:

- DESIGN C3X OR C3X-D - PRIOR TO INSTALLING PREFORMED JOINT SEALER IN THE FORMED JOINT (DETAIL C), THE JOINT SHALL BE WIDENED TO A NOMINAL WIDTH OF 3/8" BY SAWING ALONG THE FULL LENGTH OF THE FORMED JOINT.
- DESIGN C2X OR C2X-D - PRIOR TO SEALING FORMED JOINT (DETAIL C) WITH HOT POUR SEALER, THE JOINT SHALL BE WIDENED TO A NOMINAL WIDTH OF 1/2". SAW ALONG THE FULL LENGTH OF THE FORMED JOINT TO DEPTH OF 3/4" (+1/8", -1/16"). THE SEALER SHALL BE FILLED TO THE SAME DEPTH AS SHOWN IN DETAIL B.
- DESIGN C2B OR C2B-D - PRIOR TO SEALING JOINT (DETAIL B) WITH HOT POUR JOINT SEALER, A 5/8" DIA. CLOSED CELL BACKER ROD SHALL BE PLACED SUCH THAT THE TOP OF THE BACKER ROD IS 5/8" BELOW THE SURFACE OF THE PAVEMENT.
- WHEN USING PREFORMED JOINT SEALER, THE DEPTH SHALL BE 1/4" MORE THAN THE PREFORMED SEALER, WHEN COMPRESSED, TO FIT THE JOINT DESIGN WIDTH.
- THE JOINT FACES SHALL BE CLEANED AND DRIED BY SANDBLASTING AND AIR BLASTING. PRIOR TO SEALING THE JOINT, A 1/2" DIA. CLOSED CELL BACKER ROD SHALL BE PLACED SUCH THAT THE TOP OF THE BACKER ROD IS 1/2" BELOW THE SURFACE OF THE PAVEMENT. NON SELF-LEVELING SILICONE SHALL BE TOOLED INTO THE JOINT MAINTAINING A SEALANT BEAD THICKNESS OF 1/4".

GENERAL NOTES:

SEE STANDARD PLATE 1103, DOWEL BAR ASSEMBLY. SEE STANDARD PLATE 1150, CONSTRUCTION OF HEADER JOINTS. SEE STANDARD PLANS 5-297.217 AND 5-297.219, CONCRETE MAINLINE/RAMP PAVEMENT.

SEE PAVING LAYOUTS IN THE PLANS FOR JOINT CLASS DESIGNATION TO BE USED AND SPECIAL REINFORCEMENT REQUIRED.

FOR UNBONDED OVERLAYS, THE JOINT DEPTH "g" SHALL BE T/3. FOR CONCRETE PAVEMENT, THE JOINT DEPTH "g" SHALL BE T/4.

CONTRACTION JOINTS
DESIGN C

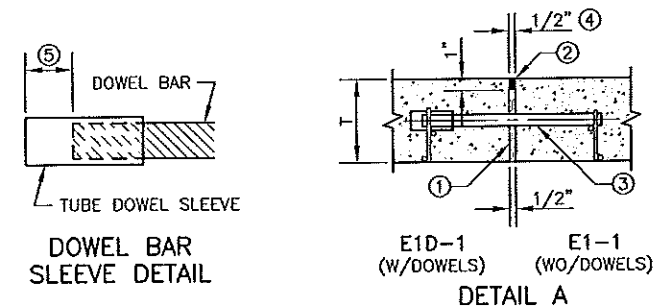

DOWEL BAR SLEEVE DETAIL

E1D-1 (W/DOWELS) E1-1 (WO/DOWELS) DETAIL A

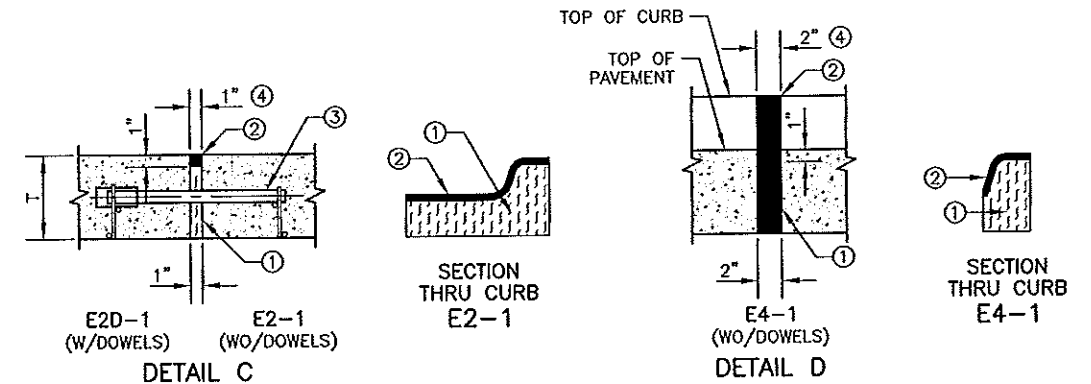

E2D-1 (W/DOWELS) E2-1 (WO/DOWELS) DETAIL C

E4-1 (WO/DOWELS) DETAIL D

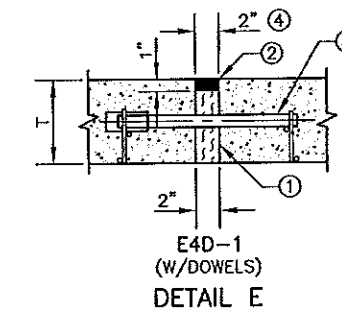

E4D-1 (W/DOWELS) DETAIL E

EXPANSION JOINTS

CLASS DESIGNATION		JOINT DETAIL	JOINT SEALER SPEC.
WITH DOWELS	WITHOUT DOWELS		
E1D-1	E1-1	A	3723
E2D-1	E2-1	C	3723
	E4-1	D	3723
E4D-1		E	3723
	E8S-1	(6)	3725

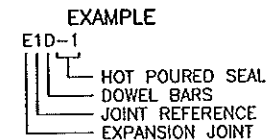
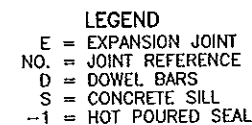

NOTES:

- PREFORMED JOINT FILLER MATERIAL, SPEC. 3702.
- JOINT SEALER SPEC. 3723. TOP OF SEALER, FLUSH TO 1/8" BELOW TOP OF PAVEMENT SURFACE. MAKE TOP OF SEALER FOR CURB SECTION E JOINTS FLUSH WITH SURFACE ±1/8".
- DOWEL BAR ASSEMBLY, SEE STANDARD PLATE 1103.
- THE FIRST NUMBER IN THE JOINT DESIGNATION IS EQUAL TO HALF OF THE JOINT NUMBER IN 1/2" INTERVALS (i.e. E1=1/2", E2=1", E4=2", AND E8=4").
- SPACE FROM END OF DOWEL BAR TO END OF SLEEVE TO BE EQUAL TO EXPANSION JOINT WIDTH.
- SEE STANDARD PLAN 5-297.223 FOR E8S JOINT DETAIL.

EXPANSION JOINTS
DESIGN E

STANDARD SHEET NO. 5-297.221 (1 OF 2)

STANDARD APPROVED: JUNE 6, 2005

TITLE:

PAVEMENT JOINTS
CONTRACTION (DESIGN C) AND EXPANSION (DESIGN E)

State Proj. No. S.A.P. 55-610-22

Sheet No. 82 of 299 Sheets

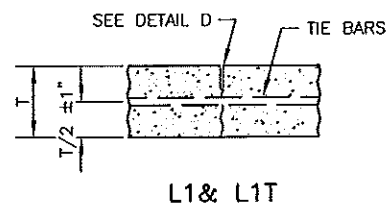

L1& L1T

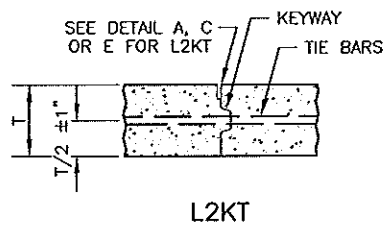

L2KT

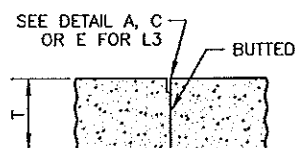

L3

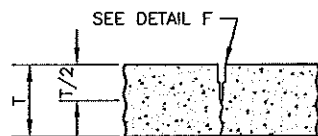

L4

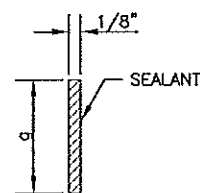

DETAIL B
(SAWED & SEALED
WITH SPEC. 3723)

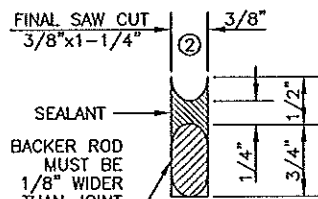

DETAIL C
(SAWED & SEALED
WITH SPEC. 3722)

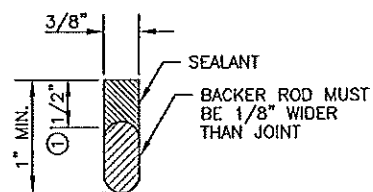

DETAIL D
(FORMED & SEALED
WITH SPEC. 3723)

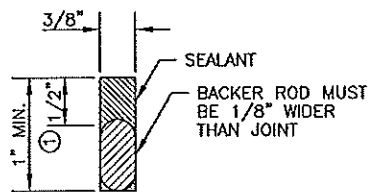

DETAIL E
(SAWED & SEALED
WITH SPEC. 3723)

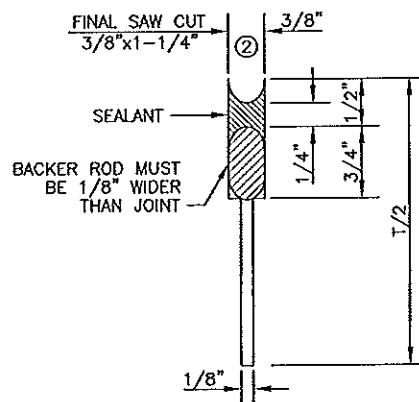

DETAIL F
(SAWED & SEALED
WITH SPEC. 3722)

LONGITUDINAL JOINT CLASS DESIGNATION,
DETAIL & SEALER SPECIFICATION TABLE

CLASS DESIGNATION				JOINT DETAIL	JOINT SEALER SPEC.
WITHOUT TIE BARS	WITH TIE BARS	WITH KEYWAY & TIE BARS	BUTTED		
L1H	L1TH			B	3723
		L2KTH		D OR E	3723
		L2KTS		C	3722
			L3H	D OR E	3723
			L3S	C	3722
L4S				F	3722

LEGEND
L = LONGITUDINAL JOINT
NO. = JOINT REFERENCE
K = KEYWAY
T = TIE BARS
U = UNSEALED
H = HOT POUR (SEALANT)
S = SILICONE (SEALANT)

JOINT REFERENCE NUMBERS
1 = SAWED TO A DEPTH OF T/3
2 = KEYED CONSTRUCTION JOINT
3 = BUTTED CONSTRUCTION JOINT
4 = SAWED TO A DEPTH OF T/2

LONGITUDINAL JOINT
DEPTH TABLE ③

PAVEMENT THICKNESS T	CONCRETE BASE JOINT DEPTH g
6"-6-1/2"	2"
7"-7-1/2"	2-1/4"
8"-8-1/2"	2-1/2"
9"-9-1/2"	3"

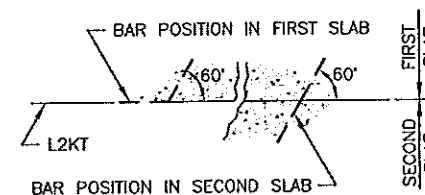

TIE BAR BENDING DETAIL

LONGITUDINAL JOINT NOTES:

ALL REBARS ARE IN METRIC DESIGNATIONS

THE TIE BAR SPACING FOR ALL L2KT JOINTS SHALL BE 2'-6" CENTER TO CENTER AND BENT 60° AS SHOWN, EXCEPT WHEN NOTED OTHERWISE IN THE PLANS.

TIE BARS IN THE L2KT JOINTS SHALL BE THE SAME SIZE AND LENGTH AS USED FOR THE L1T JOINTS, WHEN TYING PAVEMENT TO PAVEMENT. TIE BARS IN THE L2KT JOINTS SHALL BE No. 13 x 2'-6", WHEN TYING CURB & GUTTER TO PAVEMENT.

ALL TIE BARS SHALL MEET THE REQUIREMENTS OF GRADE 60 FOR AASHTO M-31 OR M-53.

NORMALLY, TIED PAVEMENT WIDTHS SHALL NOT EXCEED 4 LANES, EXCEPT BRIDGE APPROACH PANELS AND PAVEMENT TAPERS.

JOINT WIDTH TOLERANCE IS +1/16 IN. TO -1/32 IN.

FOR CONCRETE PAVEMENT, THE JOINT DEPTH "g" SHALL BE T/3 INCHES.

SPEC. 3723 SEALER - TOP OF SEALER FLUSH TO -3/16 IN. BELOW TOP OF PAVEMENT SURFACE.

① THE JOINT FACES SHALL BE CLEANED AND DRIED BY SANDBLASTING AND AIR BLASTING. PRIOR TO SEALING THE JOINT, A CLOSED CELL BACKER ROD CAPABLE OF WITHSTANDING SEALANT TEMPERATURES OF 400 DEGREES F, WITH A DIAMETER 1/8 IN. LARGER THAN THE JOINT OPENINGS, MAY BE PLACED 1/2 IN. BELOW THE TOP OF THE PAVEMENT.

② THE JOINT FACES SHALL BE CLEANED AND DRIED BY SANDBLASTING AND AIR BLASTING. PRIOR TO SEALING THE JOINT, A 1/2 IN. DIAMETER CLOSED CELL BACKER ROD SHALL BE PLACED SUCH THAT THE TOP OF THE BACKER ROD IS 1/2 IN. BELOW THE SURFACE OF THE PAVEMENT. NON SELF-LEVELING SILICONE SHALL BE TOOLED INTO THE JOINT MAINTAINING A SEALANT BEAD THICKNESS OF 1/4 IN.

GENERAL NOTES:

SEE STANDARD PLATE 1103, DOWEL BAR ASSEMBLY. SEE STANDARD PLATE 1141, PAVEMENT KEYWAY. SEE STANDARD PLANS 5-297.217 AND 5-297.219 FOR CONCRETE MAINLINE AND RAMP PAVEMENT.

SEE PAVING LAYOUTS IN THE PLANS FOR JOINT CLASS DESIGNATIONS TO BE USED AND SPECIAL REINFORCEMENT REQUIRED.

STANDARD SHEET NO.
5-297.221 (2 OF 2)
STANDARD APPROVED:
JUNE 6, 2005

TITLE:

PAVEMENT JOINTS
LONGITUDINAL (DESIGN L)

State Proj. No. S.A.P. 55-610-22

Sheet No. 83 of 299 Sheets